

**Report Number: QIP-ASR121995**

**Audit Date :** 10 Oct., 2012  
**Expiry Date :** 09 Oct., 2013

This report is issued by Focus Technology Co., Ltd. (Made-in-China.com) and the supervising inspectorate (SGS-CSTC Standards Technical Services Co., Ltd.) to confirm that:

**Company Name :** Zhuhai Aowei Electronics Co., Ltd.  
 珠海市傲威电子有限公司  
**Showroom :** <http://cnourway.en.made-in-china.com/>  
**Address :** 4/F Rirong Road Edifice, No. 291 People's West Road, Xiangzhou, Zhuhai, Guangdong, China  
**Product :** Ink Cartridge, Toner Cartridge, Ink, Photo Paper

has been on site audited for the Following Scope of Activity

1. General Information
  2. Foreign Trade Capacity
  3. Production Capacity & Quality Control
- the audit content of this part relates only to its associated enterprise
4. Photos



**General Comments:**

Zhuhai Aowei Electronics Co., Ltd. is a trading company with 43 employees, which subsidiary company ( Kingway Image Co., Ltd. ) is a manufacturer 179 employees, and the general name is Ourway Image Co., Ltd. Then Zhuhai Aowei Electronics Co., Ltd. was established in 2006, located in 4/F Rirong Road Edifice, No. 291 People's West Road, Xiangzhou, Zhuhai, Guangdong, China. The company occupy an area of more than 442 square meters. And the main products included: ink cartridge, toner cartridge, ink, photo paper.

Sign for and on behalf of  
 SGS-CSTC Standards Technical Services Co., Ltd.

This document is issued by the Company under its General Conditions of Service accessible at [http://www.sgs.com/terms\\_and\\_conditions.htm](http://www.sgs.com/terms_and_conditions.htm). Attention is drawn to the limitation of liability, indemnification and jurisdiction issues defined therein. Any holder of this document is advised that information contained hereon is solely limited to visual examination of the safely and readily accessible portions of the consignment and reflects the Company's findings at the time of its intervention only and within the limits of Client's instructions, if any. The Company's sole responsibility is to its Client and this document does not exonerate parties to a transaction from exercising all their rights and obligations under the transaction documents. Any unauthorized alteration, forgery or falsification of the content or appearance of this document is unlawful and offenders may be prosecuted to the fullest extent of the law.

Attention: To check the authenticity of testing / inspection report & certificate, please contact us at telephone: (86-755)83071443, or email: [CN.Doccheck@sgs.com](mailto:CN.Doccheck@sgs.com)

# SUPPLIER ASSESSMENT REPORT

Audited Company	Zhuhai Aowei Electronics Co., Ltd. 珠海市傲威电子有限公司
Audited Site:	4/F Rirong Road Edifice, No. 291 People's West Road, Xiangzhou, Zhuhai, Guangdong, China

Consigner of Assessment	Made-in-China.com		
Audit Type	<input type="checkbox"/> Initial Audit <input checked="" type="checkbox"/> Re-audit		
Valid Date	From 10 Oct., 2012 to 09 Oct., 2013	Verify Report	<a href="http://www.sgs.com">www.sgs.com</a>
Auditor	Lynn Hu	Reviewed by	Roger Wang

## CONTENTS

- Part A: General Information**
  - Section 1: Company Overview
  - Section 2: Human Resources
- Part B: Foreign Trade Capacity**
  - Section 1: Export Overall Situation
  - Section 2: Export Business Capacity
  - Section 3: Supplier Management
  - Section 4: After-sales Service Capacity
- Part C: Product Research & Development Capacity**
  - Section 1: Product Research & Development Capacity
- Part D: Management System and Product Certification**
  - Section 1: Management System(s) and Product Certification
- Part E: Production Capacity & Quality Control**
  - Section 1: Production Capacity Section
  - Section 2: Production Process Control
- Part F: Financial Position**
  - Section 1: Financial Data
  - Section 2: Key Performance Indications
  - Section 3: Banking
  - Section 4: Product Insurance
- Part G: Working Environment**
  - Section 1: Working Environment
- Part H: Energy Saving and Emission Reduction**
  - Section 1: Environmental Management
  - Section 2: Water, Gas and Noise Control
- Part I: Industry Information**
  - Section 1: Industry Information
- Part J: Photos**
  - Section 1: Photos of Documents
  - Section 2: Photos of Company

This document is issued by the Company under its General Conditions of Service accessible at [http://www.sgs.com/terms\\_and\\_conditions.htm](http://www.sgs.com/terms_and_conditions.htm). Attention is drawn to the limitation of liability, indemnification and jurisdiction issues defined therein. Any holder of this document is advised that information contained hereon is solely limited to visual examination of the sample and readily accessible portions of the consignment and reflects the Company's findings at the time of its intervention only and within the limits of Client's instructions. If any of the Company's sole responsibility is to its Client and this document does not exonerate parties to a transaction from exercising all their rights and obligations under the transaction documents, any unauthorized alteration, forgery or falsification of the content or appearance of this document is unlawful and offenders may be prosecuted to the fullest extent of the law.

Attention: To check the authenticity of testing / inspection report & certificate, please contact us at telephone: (86-755)83071443, or email: [CN.Doccheck@sgs.com](mailto:CN.Doccheck@sgs.com)

Page No.: 2 of 12



## Part A: General Information

### Section 1: Company Overview

1.1 Legal Validity			
Does the company have a valid business license?	<input checked="" type="checkbox"/> Yes <input type="checkbox"/> No <input type="checkbox"/> Others	Registration Number	440400000185845
Year of established	24 Mar., 2006	Valid Date	24 Mar., 2016
Registered address	4/F Rirong Road Edifice, No. 291 People's West Road, Xiangzhou, Zhuhai, Guangdong, China		
Actual address	4/F Rirong Road Edifice, No. 291 People's West Road, Xiangzhou, Zhuhai, Guangdong, China		
Is the annual review done by local authority (Industrial & Commercial Bureau)?	The company passed annual review in 2012		
Registered capital	RMB 500,000		
Name of legal representative	Mr. Zhixiang Zhao		
Business scope	Commercial wholesale, retail (need to other administrative licensing project except, laws and regulations may not prohibit the operation); System integration, computer system service		
1.2 Basic Information			
Contact person	Ms. Liu	Email	<a href="mailto:marketing@outwayink.com">marketing@outwayink.com</a>
Phone number	0086-756-2628632	Fax number	0086-756-2622492
URL/Web address	<a href="http://cnourway.en.made-in-china.com/">http://cnourway.en.made-in-china.com/</a>		
Company type	<input type="checkbox"/> Manufacturer <input checked="" type="checkbox"/> Trading Company <input type="checkbox"/> Combined <input type="checkbox"/> Group Corporation		
Type of ownership	<input checked="" type="checkbox"/> Limited Company <input type="checkbox"/> Public Company <input type="checkbox"/> Foreign joint venture <input type="checkbox"/> State-Owned <input type="checkbox"/> Private Owner <input type="checkbox"/> Wholly foreign-owned enterprises		
Subsidiary company	n Company name: Kingway Image Co., Ltd. The relationship of two companies: <input checked="" type="checkbox"/> The two companies have the same legal representative <input type="checkbox"/> One company has more than <b>20%</b> of the shares of another company		
Products manufactured / sold scope	Ink Cartridge, Toner Cartridge, Ink, Photo Paper		
1.3 Company Building Information			
According to:			
<input type="checkbox"/> Land certificate <input type="checkbox"/> Real estate certificate <input checked="" type="checkbox"/> Lease agreement <input type="checkbox"/> Observation Estimated on site			
The plant area 442 square meters			
The land occupies 442 square meters.			
The offices occupy 442 square meters.			
The workshops occupy / square meters.			

This document is issued by the Company under its General Conditions of Service accessible at [http://www.sgs.com/terms\\_and\\_conditions.htm](http://www.sgs.com/terms_and_conditions.htm). Attention is drawn to the limitation of liability, indemnification and jurisdiction issues defined therein. Any holder of this document is advised that information contained hereon is solely limited to visual examination of the sample and readily accessible portions of the consignment and reflects the Company's findings at the time of its intervention only and within the limits of Client's instructions. If any of the Company's sole responsibility is to its Client and this document does not exonerate parties to a transaction from exercising all their rights and obligations under the transaction documents, any unauthorized alteration, forgery or falsification of the content or appearance of this document is unlawful and offenders may be prosecuted to the fullest extent of the law.

Attention: To check the authenticity of testing / inspection report & certificate, please contact us at telephone: (86-755)83071443, or email: [CN.Doccheck@sgs.com](mailto:CN.Doccheck@sgs.com)

Page No.: 3 of 12



**Section 2: Human Resources**

**2.1 Company Chart**

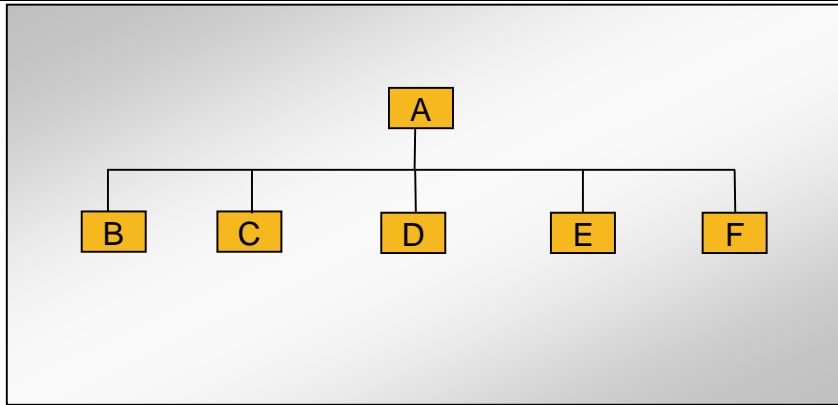

**2.2 Explanation of Code and Employee Details**

Code	Department	Number of employees
A	Board chairman	1
B	Sales depart	21
C	Marketing depart	4
D	Logistics depart	8
E	Admin depart	3
F	Financial depart	6
<b>Number in total:</b>		43

**2.3 Key Staff**

Title	Full name	Education	Working experience for this trade / total experience
Board chairman	Mr. Zhixiang Zhao	University	12 years

Remark: Above information of key staff was based on interview with company representative.

This document is issued by the Company under its General Conditions of Service accessible at [http://www.sgs.com/terms\\_and\\_conditions.htm](http://www.sgs.com/terms_and_conditions.htm). Attention is drawn to the limitation of liability, indemnification and jurisdiction issues defined therein. Any holder of this document is advised that information contained hereon is solely limited to visual examination of the sample and readily accessible portions of the consignment and reflects the Company's findings at the time of its intervention only and within the limits of Client's instructions. If any of the Company's sole responsibility is to its Client and this document does not exonerate parties to a transaction from exercising all their rights and obligations under the transaction documents. Any unauthorized alteration, forgery or falsification of the content or appearance of this document is unlawful and offenders may be prosecuted to the fullest extent of the law.

Attention: To check the authenticity of testing / inspection report & certificate, please contact us at telephone: (86-755)83071443, or email: [CN.Doccheck@sgs.com](mailto:CN.Doccheck@sgs.com)



## Part B: Foreign Trade Capacity

### Section 1: Export Overall Situation

1.1 Export Overall Situation	
Does the company have a valid Import and Export license?	<input checked="" type="checkbox"/> Yes <input type="checkbox"/> No
The import and export enterprise code.	4404786472607
The number of foreign trading staff with relevant trading experience.	<input type="checkbox"/> within 1 year staff <input checked="" type="checkbox"/> 1-5 years 10 staffs <input checked="" type="checkbox"/> 6-10 years 11 staffs <input checked="" type="checkbox"/> over 10 years 1 staff Total 22 staffs
The language freely used by foreign trade staff	<input checked="" type="checkbox"/> English <input checked="" type="checkbox"/> others: Japanese & Russian & Spanish
Annual revenue of previous year	The company did not provide financial report for reference
Annual export revenue of previous year	The company did not provide financial report for reference
Estimated export revenue for this year.	Base on the representative's description, the export revenue target was RMB 150 million in 2012
Overseas agent	Nil
Nearest port	Zhuhai port
Acceptable quotation terms	<input checked="" type="checkbox"/> FOB <input checked="" type="checkbox"/> CIF <input type="checkbox"/> CFR
Acceptable payment terms	<input checked="" type="checkbox"/> LC <input checked="" type="checkbox"/> T/T <input type="checkbox"/> D/P <input type="checkbox"/> PayPal <input type="checkbox"/> Western Union <input type="checkbox"/> Small-amount payment
Average lead time	<input checked="" type="checkbox"/> within 15 workday <input type="checkbox"/> one month <input type="checkbox"/> 2-3 months <input type="checkbox"/> 4-6 months <input type="checkbox"/> 6-12 months <input type="checkbox"/> more time

### Section 2: Export Business Capacity

2.1 Market Distribution (please list top three areas)		
Market	Main Product	Main client
<input type="checkbox"/> North America		
<input type="checkbox"/> South America		
<input type="checkbox"/> Europe		
<input checked="" type="checkbox"/> Southeast Asia/ Mideast	Ink Cartridge, Toner Cartridge, Ink, Photo Paper	The company kept it as a secret
<input type="checkbox"/> Africa		
<input type="checkbox"/> East Asia (Japan/ South Korea)		
<input checked="" type="checkbox"/> Domestic	Ink Cartridge, Toner Cartridge, Ink, Photo Paper	The company kept it as a secret
<input type="checkbox"/> Others		

This document is issued by the Company under its General Conditions of Service accessible at [http://www.sgs.com/terms\\_and\\_conditions.htm](http://www.sgs.com/terms_and_conditions.htm). Attention is drawn to the limitation of liability, indemnification and jurisdiction issues defined therein. Any holder of this document is advised that information contained hereon is solely limited to visual examination of the sample and readily accessible portions of the consignment and reflects the Company's findings at the time of its intervention only and within the limits of Client's instructions. If any of the Company's sole responsibility is to its Client and this document does not exonerate parties to a transaction from exercising all their rights and obligations under the transaction documents. Any unauthorized alteration, forgery or falsification of the content or appearance of this document is unlawful and offenders may be prosecuted to the fullest extent of the law.

Attention: To check the authenticity of testing / inspection report & certificate, please contact us at telephone: (86-755)83071443, or email: [CN.Doccheck@sgs.com](mailto:CN.Doccheck@sgs.com)

Page No.: 5 of 12



### Section 3: Supplier Management

3.1 Supplier Management		
Item	Content	Observations /Comments
1	Does the company establish and implement an effective suppliers' assessment procedure?	<input type="checkbox"/> Have the written procedures and followed records <input type="checkbox"/> Have the written procedures but no records <input type="checkbox"/> Have relevant records without written procedure <input checked="" type="checkbox"/> No written procedures or followed records
2	Does the company have an updated list of approved suppliers?	<input type="checkbox"/> The approved suppliers list was updated in _____ <input type="checkbox"/> Have the written suppliers without approved signature or date. <input type="checkbox"/> Provided some suppliers names <input checked="" type="checkbox"/> No approved suppliers list

### Section 4: After-sales Service Capacity

4.1 After-sales Service Capacity		
Item	Content	Observations /Comments
1	Is there a procedure to conduct random product inspection after final packaging in place?	<input type="checkbox"/> Have clear standards and written inspection records <input type="checkbox"/> No written standards but had inspection reports <input type="checkbox"/> Have the procedures but no inspection records <input checked="" type="checkbox"/> It's not necessary to carry out the inspection
2	Is there a clear procedure for handling customer complaints?	<input type="checkbox"/> Has the clear procedure and followed records <input checked="" type="checkbox"/> Has the procedure but no written records. <input type="checkbox"/> No written procedures or records.
3	Can the finished/package product be traced by lot identification to the appropriate raw materials test reports?	<input type="checkbox"/> Have the procedures to trace the raw materials. <input type="checkbox"/> Can trace main materials <input checked="" type="checkbox"/> Can trace production date. <input type="checkbox"/> Can't trace products
4	Are corrective & preventive actions mechanism established and implemented effectively (including the suppliers/ sub-contractors control, incoming inspection, process control, final inspection and customer complaint)?	<input type="checkbox"/> Has the clear procedure and followed records <input type="checkbox"/> Has the procedure but no written records. <input checked="" type="checkbox"/> No written procedures or records.

This document is issued by the Company under its General Conditions of Service accessible at [http://www.sgs.com/terms\\_and\\_conditions.htm](http://www.sgs.com/terms_and_conditions.htm). Attention is drawn to the limitation of liability, indemnification and jurisdiction issues defined therein. Any holder of this document is advised that information contained hereon is solely limited to visual examination of the sample and readily accessible portions of the consignment and reflects the Company's findings at the time of its intervention only and within the limits of Client's instructions. If any of the Company's sole responsibility is to its Client and this document does not exonerate parties to a transaction from exercising all their rights and obligations under the transaction documents. Any unauthorized alteration, forgery or falsification of the content or appearance of this document is unlawful and offenders may be prosecuted to the fullest extent of the law.

Attention: To check the authenticity of testing /inspection report & certificate, please contact us at telephone: (86-755)83071443, or email: [CN.Doccheck@sgs.com](mailto:CN.Doccheck@sgs.com)

Page No.: 6 of 12

## Part E: Production Capacity & Quality Control

Remark: The audit content of this part relates only to its associated enterprise (Kingway Image Co., Ltd.)

### Section 1: Production Capacity

#### 1.1 Production Workflow Chart



#### 1.2 Products Situation (Top three Product Categories)

Product Category	Capacity in Top Month	Average Capacity	Total in 2011
<p><b>Description:</b> ink cartridges</p>	The company kept it as a secret	The company kept it as a secret	The company kept it as a secret
<p><b>Description:</b> toner cartridges</p>	The company kept it as a secret	The company kept it as a secret	The company kept it as a secret

#### 1.3 Main Facilities

Picture	Facility name	Brand or Country/Region of origin	Quantity
---------	---------------	-----------------------------------	----------

This document is issued by the Company under its General Conditions of Service accessible at [http://www.sgs.com/terms\\_and\\_conditions.htm](http://www.sgs.com/terms_and_conditions.htm). Attention is drawn to the limitation of liability, indemnification and jurisdiction issues defined therein. Any holder of this document is advised that information contained hereon is solely limited to visual examination of the safety and readily accessible portions of the consignment and reflects the Company's findings at the time of its intervention only and within the limits of Client's instructions, if any. The Company's sole responsibility is to its Client and this document does not exonerate parties to a transaction from exercising all their rights and obligations under the transaction documents. Any unauthorized alteration, forgery or falsification of the content or appearance of this document is unlawful and offenders may be prosecuted to the fullest extent of the law.

Attention: To check the authenticity of testing / inspection report & certificate, please contact us at telephone: (86-755)83071443, or email: [CN.Doccheck@sgs.com](mailto:CN.Doccheck@sgs.com)

	Welding machine	China	12
	Heat-sealed machine	China	54
	Ink assembly machine	China	17
	Sponge assembly machine	China	8
	Printer	China	89
	Marking machine	China	2

This document is issued by the Company under its General Conditions of Service accessible at [http://www.sgs.com/terms\\_and\\_conditions.htm](http://www.sgs.com/terms_and_conditions.htm). Attention is drawn to the limitation of liability, indemnification and jurisdiction issues defined therein. Any holder of this document is advised that information contained hereon is solely limited to visual examination of the safely and readily accessible portions of the consignment and reflects the Company's findings at the time of its intervention only and within the limits of Client's instructions. If any of the Company's sole responsibility is to its Client and this document does not exonerate parties to a transaction from exercising all their rights and obligations under the transaction documents, any unauthorized alteration, forgery or falsification of the content or appearance of this document is unlawful and offenders may be prosecuted to the fullest extent of the law.

Attention: To check the authenticity of testing / inspection report & certificate, please contact us at telephone: (86-755)83071443, or email: [CN.Doccheck@sgs.com](mailto:CN.Doccheck@sgs.com)

Page No.: 8 of 12





## Section 2: Production Process Control

2.1 Production Process Control		
Item	Content	Observations /Comments
1	Product R&D capacity	<input type="checkbox"/> Own brand <input checked="" type="checkbox"/> ODM <input checked="" type="checkbox"/> OEM
2	Are the environmental conditions, such as tidiness and cleanliness being controlled and suitable for the operation performed?	<input type="checkbox"/> Very tidy <input checked="" type="checkbox"/> Normal <input type="checkbox"/> Need to improve <input type="checkbox"/> Very poor
3	Are the necessary items /documents provided at appropriate location and under control?	<input checked="" type="checkbox"/> Work Instructions /procedures <input type="checkbox"/> Workmanship standard /acceptance <input type="checkbox"/> Golden sample /Approval sample <input type="checkbox"/> Product picture <input type="checkbox"/> Verbal by workshop director
4	Are written instructions available for incoming material inspections /testing? Is the relevant record maintained?	<input checked="" type="checkbox"/> Has instructions and uniformly followed <input type="checkbox"/> Has instruction but no written records <input type="checkbox"/> Materials checked by storage staff
5	Are written inspections /testing instructions available for finished products? Is the relevant record maintained?	<input checked="" type="checkbox"/> Have instructions and uniformly followed <input type="checkbox"/> Have instruction but no written records <input type="checkbox"/> Finished product checked by packing staff
6	What type of inspection is used for finished products?	<input checked="" type="checkbox"/> Random inspection <input type="checkbox"/> Visual inspection <input checked="" type="checkbox"/> Function inspection <input checked="" type="checkbox"/> 100% inspection <input checked="" type="checkbox"/> Visual inspection <input type="checkbox"/> Function inspection
7	Are non-conforming units clearly marked/ segregated to prevent accidental dispatch?	<input checked="" type="checkbox"/> Marked and segregated <input type="checkbox"/> Segregated but not marked clearly <input type="checkbox"/> Not found on site
8	How are the non-conforming units handled?	<input checked="" type="checkbox"/> Repaired and re-inspection <input type="checkbox"/> Picked out <input type="checkbox"/> Used under control <input type="checkbox"/> Others

This document is issued by the Company under its General Conditions of Service accessible at [http://www.sgs.com/terms\\_and\\_conditions.htm](http://www.sgs.com/terms_and_conditions.htm). Attention is drawn to the limitation of liability, indemnification and jurisdiction issues defined therein. Any holder of this document is advised that information contained hereon is solely limited to visual examination of the sample and readily accessible portions of the consignment and reflects the Company's findings at the time of its intervention only and within the limits of Client's instructions. If any of the Company's sole responsibility is to its Client and this document does not exonerate parties to a transaction from exercising all their rights and obligations under the transaction documents. Any unauthorized alteration, forgery or falsification of the content or appearance of this document is unlawful and offenders may be prosecuted to the fullest extent of the law.

Attention: To check the authenticity of testing /inspection report & certificate, please contact us at telephone: (86-755)83071443, or email: [CN.Doccheck@sgs.com](mailto:CN.Doccheck@sgs.com)

Page No.: 9 of 12



Part J: Photos

Section 1: Photos of Documents

1.1 Photos of Documents

Description: Business License



Description: Business License ( Its Associated Enterprise )



Description: Lease Agreement

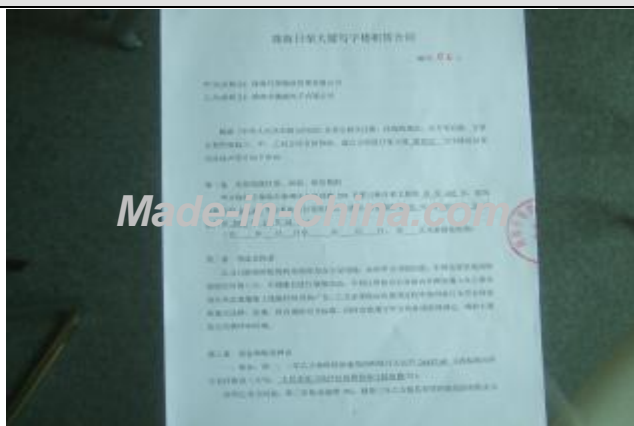

Description: Lease Agreement ( Its Associated Enterprise )



Description: Export License









This document is issued by the Company under its General Conditions of Service accessible at [http://www.sgs.com/terms\\_and\\_conditions.htm](http://www.sgs.com/terms_and_conditions.htm). Attention is drawn to the limitation of liability, indemnification and jurisdiction issues defined therein. Any holder of this document is advised that information contained hereon is solely limited to visual examination of the safely and readily accessible portions of the consignment and reflects the Company's findings at the time of its intervention only and within the limits of Client's instructions, if any. The Company's sole responsibility is to its Client and this document does not exonerate parties to a transaction from exercising all their rights and obligations under the transaction documents. Any unauthorized alteration, forgery or falsification of the content or appearance of this document is unlawful and offenders may be prosecuted to the fullest extent of the law.

Attention: To check the authenticity of testing / inspection report & certificate, please contact us at telephone: (86-755)83071443, or email: [CN.Doccheck@sgs.com](mailto:CN.Doccheck@sgs.com)

**Section 2: Photos of Company**

**2.1 Photos of Company and Product Sample**

<p>Description: Company Gate</p>	<p>Description: Company Gate ( Its Associated Enterprise )</p>
	
<p>Description: Office</p>	<p>Description: Workshop ( Its Associated Enterprise )</p>
	
<p>Description: Workshop ( Its Associated Enterprise )</p>	<p>Description: Warehouse ( Its Associated Enterprise )</p>
	

This document is issued by the Company under its General Conditions of Service accessible at [http://www.sgs.com/terms\\_and\\_conditions.htm](http://www.sgs.com/terms_and_conditions.htm). Attention is drawn to the limitation of liability, indemnification and jurisdiction issues defined therein. Any holder of this document is advised that information contained hereon is solely limited to visual examination of the safely and readily accessible portions of the consignment and reflects the Company's findings at the time of its intervention only and within the limits of Client's instructions, if any. The Company's sole responsibility is to its Client and this document does not exonerate parties to a transaction from exercising all their rights and obligations under the transaction documents. Any unauthorized alteration, forgery or falsification of the content or appearance of this document is unlawful and offenders may be prosecuted to the fullest extent of the law.

Attention: To check the authenticity of testing / inspection report & certificate, please contact us at telephone: (86-755)83071443, or email: [CN.Doccheck@sgs.com](mailto:CN.Doccheck@sgs.com)

Description: Showroom



Description: Showroom



Description: Showroom



Description: Showroom



-- End of the Report --

This document is issued by the Company under its General Conditions of Service accessible at [http://www.sgs.com/terms\\_and\\_conditions.htm](http://www.sgs.com/terms_and_conditions.htm). Attention is drawn to the limitation of liability, indemnification and jurisdiction issues defined therein. Any holder of this document is advised that information contained hereon is solely limited to visual examination of the safely and readily accessible portions of the consignment and reflects the Company's findings at the time of its intervention only and within the limits of Client's instructions. If any of the Company's sole responsibility is to its Client and this document does not exonerate parties to a transaction from exercising all their rights and obligations under the transaction documents, any unauthorized alteration, forgery or falsification of the content or appearance of this document is unlawful and offenders may be prosecuted to the fullest extent of the law.

Attention: To check the authenticity of testing / inspection report & certificate, please contact us at telephone: (86-755)83071443, or email: [CN.Doccheck@sgs.com](mailto:CN.Doccheck@sgs.com)